







LOW PROFILE MULTI RIDE OPERATION MANUAL

Galaxy America, Inc.

 7431 Sawyer Circle, Port Charlotte, FL 33981

 941 697 0324

 941 697 1249

 sales@galaxymultirides.com

 www.galaxymultirides.com

 GalaxyMultiRides

 GalaxyBulls

 GalaxyBulls

 GalaxyMultiRides



Welcome and thank you for purchasing the Galaxy Low Profile Multi Ride system.

**Please take some time and read through the contents of this manual
BEFORE you use your machine.**

All operators who will use the Galaxy Low Profile Multi Ride **MUST read** this manual to ensure a **safe operation** for your customers.

TABLE OF CONTENTS

1. Welcome	3
2. Rides for the Low Profile Motion Base	4
3. What's in the Box. Components	5
4. Electrical Information	5
5. Setting Up Your Low Profile Motion Base	6
6. Set Up Diagram	9
7. Operating Your Low Profile Motion Base	10
8. Rules of Play	13
9. Serial Number Location	14
10. Trouble Shooting	15
11. Maintenance	18
12. Safety Check Routine	19
13. Low Profile Motion Base Lubrication Points	20
14. Risk Assessment	21
15. Release of Liability and Assumptions of Risk	22
16. Incident Report	23
17. FR Test Certificates	24
18. Manufacturer's Inspection	28
19. Terms and Conditions of Sale	29
20. Appendix: Electrical Operation & Trouble Shooting	36



Welcome!

All equipment manufactured by Galaxy Multi Rides is designed with a high regard for safety as well as operational ease.

The information contained within this manual will assist you and your operators in producing safe and enjoyable entertainment for your clients.

This instruction manual has been supplied for the purpose of assisting you in the proper and safe operation of your new Galaxy Multi Rides game. You can also find this manual on line in our website. Look for "Safety and Training" under the "Resource" tab in www.galaxymultirides.com. You can also view our safety video ("How To" playlist) on our YouTube channel (www.youtube.com/galaxybulls).

This manual will also guide you through the proper set up procedures, ensuring the safest and most enjoyable experience for your clientele, and maintenance recommendations that will facilitate top performance and a long life for your game. Your inflatable attraction is constructed by following the procedures and using quality materials, all in compliance with the ASTM standards.

Galaxy Multi Rides takes great pride in delivering to you inflatable games manufactured, inspected and tested with a focus on the highest safety standards and top quality workmanship. Additionally, many other inspections and tests are performed to ensure your new game meets the first class standards of Galaxy Multi Rides.

Safety is everybody's major concern. At Galaxy we go to great lengths to ensure that our products are the safest on the market. On our website (look for "Safety and Training" under the "Resource" tab in www.galaxymultirides.com), there's a training Safety Questionnaire that you can complete on line. **PLEASE, read this manual thoroughly and complete the questionnaire for every member of staff who's going to operate the ride.** All the answers to the questions are in this manual.

By having a quality safe machine and competent operators, this can only be a good thing, which will result in more cost effective insurance for everyone.

If you experience any difficulty in any of the procedures set forth in this manual, please call 941 697 0324.



Robin Whincup
President of Galaxy Multi Rides



Rides for the Low Profile Motion Base



Halfpipe Snowboard



Halfpipe Skateboard



Halfpipe Surfboard



Big Wave Surfboard



Angus McRodeo and the Farmacyard Collection



Low Wave Surfboard

What's in the Box



- | | |
|---------------------------|---------------------------|
| 1 x Motion Base | 1 x Protective Pad |
| 4 x Steel Stabiliser Legs | 1 x Blower |
| 2 x Wheels | 1 x Multi Ride Attachment |
| 1 x Control Console | for Surf Machine / 3 x |
| 1 x Main Power Cable | Multi Ride attachments |
| 1 x 6-Pin Cable | for Xtreme Board Combo |
| 1 x Inflatable | 1 x 19mm Spanner |

Electrical Information

CONTROL CONSOLE

Operates from 110 volts single phase electricity 60hz. drawing 16 amps.



1. Time Clock
2. Emergency Stop Button
3. Automatic Programs
4. Stop Button
5. Mains Power
6. Spin Dial
7. Direction Control

WARNING

SWITCH OFF THE MAINS POWER BEFORE WORKING ON THE CONTROL CONSOLE AND MOTION BASE. ALL WORKS MUST BE CARRIED OUT BY A QUALIFIED ELECTRICIAN. **ELECTRIC CURRENT CAN KILL YOU.**



Setting Up Your Low Profile Motion Base

1.



Place the motion system in position on a clean, dry and flat surface. Insert the four stabiliser legs into the base and tighten the nuts with 19mm. wrench.

2.

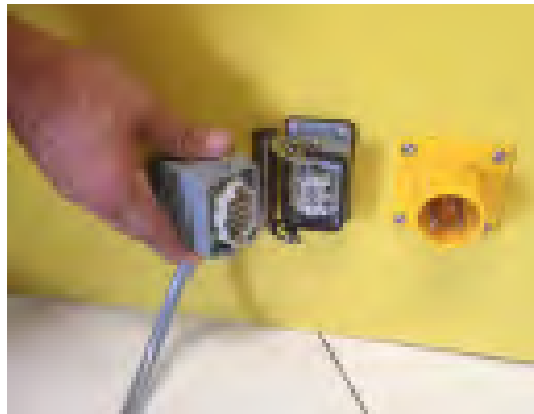

Plug in the power leads to the motion base from the control console. Plug in the mains power supply lead. The plugs on the motion base must be adjacent with the console. **NEVER TWIST THE CABLES GOING TO THE MOTION BASE.**

3.

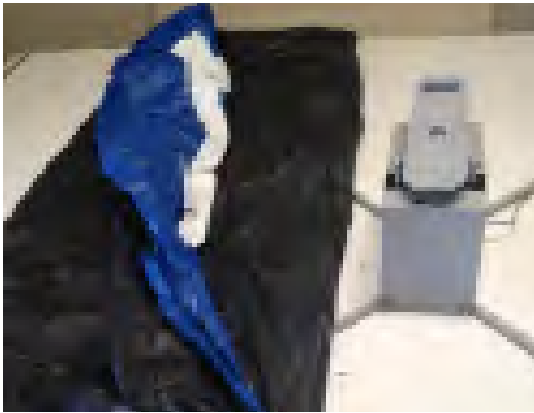

Unroll the inflatable and position it over the motion system.



Make sure the velcro deflation flap is closed (colors may vary from the ones pictured).

Please note: the Emergency Stop button MUST ALWAYS BE DEPRESSED AND THE KEY REMOVED whenever you are setting up the ride or leaving the control console unattended.



Setting Up Your Low Profile Motion Base

4.



Make sure the mounting bracket is loose. Attach the desired ride to the motion system. Place the sub frame in position and pull towards the back.



You will feel the sub frame slide under the brackets on the motion base. By gently attempting to lift the ride attachment you can check that it is secured under the front bracket.



First, tighten the 12mm. by 1mm. draw bolt. Do not over torque it at this time. Now, tighten the two 12mm. bolts to clamp down the bracket with the 19mm. wrench doing 3 or 4 turns on each bolt at a time. These two bolts draw the frame back onto the mounting bracket.



Finally, tighten the 12mm. by 1mm. draw bolt until the ride frame is pulled back fully. Now, tighten up the locking nut on the draw bolt. This bolt pulls the frame down onto the motion base. **IT'S NOT NECESSARY TO OVER TIGHTEN THE BOLTS.**

Please note: the Emergency Stop button **MUST ALWAYS BE DEPRESSED AND THE KEY REMOVED** whenever you are setting up the ride or leaving the control console unattended.



Setting Up Your Low Profile Motion Base

5.



Pull the blow tube over the blower and secure it with the belt attached. Inflation should be the last stage to be done.

6.



Anchor the inflatable by the 4 anchor points in the low wall bed, and the 7 anchor points in the big wave bed (see next page). Use 0.625" diameter steel stakes either straight up or up to a 15 degree angle on soft ground (18" into the ground) or 75lbs. at each of the 4 anchor points in the sand/water weight on hard ground (or indoor location) are appropriate anchor tools (colors may vary from the ones pictured).

7.



Turn the Mains Power switch in the control console on, then the key in the Emergency Stop button, and now you are ready to have fun in your Galaxy Multi Ride.

PLEASE NOTE

If you are operating on soft ground (eg: grass or sand), ensure that the motion base is placed on two sheets of 8ft. x 4 ft. x 1in. thick plywood. This would ensure that the motion base does NOT dig into the ground. **DO NOT EVER FASTEN THE MOTION BASE TO THE FLOOR, UNDER ANY CIRCUMSTANCES.**

Please note: the Emergency Stop button MUST ALWAYS BE DEPRESSED AND THE KEY REMOVED whenever you are setting up the ride or leaving the control console unattended.



Set Up Diagram

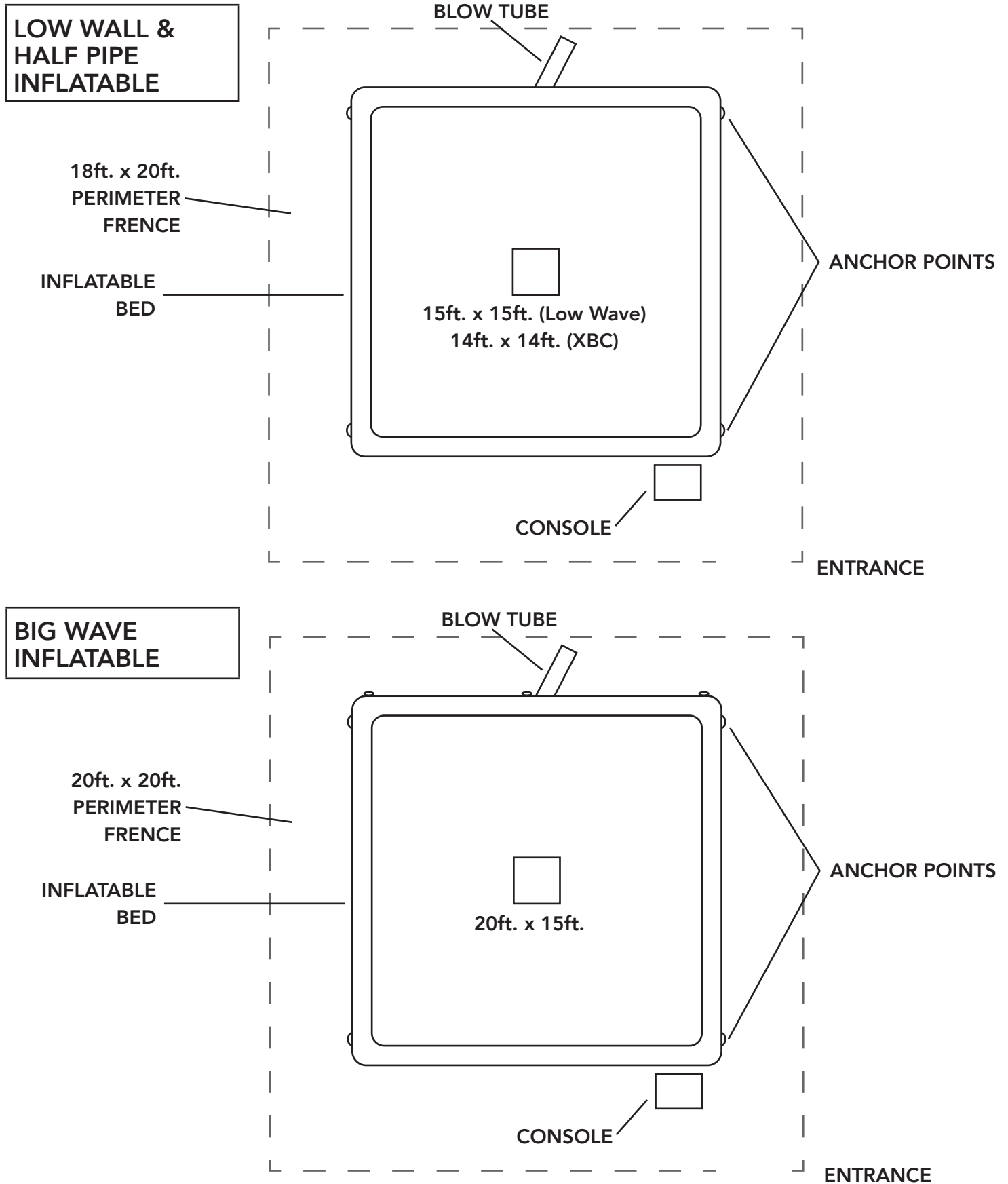

Operating Your Low Profile Motion Base

1. FASCIA PANEL

Switch the power on by turning the red & yellow isolator switch to "ON". Ensure you release the Emergency Stop button by turning the key to the right. You will hear a click, the LED clocks and program buttons will illuminate.

2. AUTOMATIC PROGRAMS

There are 3 automatic programs varying in difficulty. Each of these programs are linked to the LED clocks enabling you to time the ride.

- Number 1: Slow speed for first time and less confident riders.
- Number 2: Medium speed for more confident riders.
- Number 3: Fast speed for riders who are very confident.

3. NUMBER OF RIDERS

Never allow more than ONE rider on the machine at any one time.

4. RIDER PREPARATION

Ensure that all riders remove footwear, eye wear, cell phones, neck wear and any sharp items on their person.

All riders must read the rules of play and sign the waiver. Verbally warn them that they will be thrown from the ride. If the rider has any doubt, they must NOT RIDE.

5. OPERATING THE RIDE

Ensure that the rider stands in the center of the ride. Once the rider is ready, the operator can commence the ride.

Start the ride on the slowest program (#1); as the rider gains confidence the operator can change the program to #2 and then #3. The clocks will start when you start the ride and will stop when the ride stops.

Always advise the rider that you are increasing the difficulty. If the rider does not want to go faster, respect their decision.

The operator must keep their finger over the

stop button and constantly watch the rider. If the operator feels the rider is about to fall they can stop the ride at any time by pressing the stop button.

There is no set time for this ride: it is determined by how long the rider is able to stay on the ride.

Once the rider has dismounted from the ride, the operator must instruct the rider to exit the inflatable cushion via the doorway. **DO NOT ALLOW another rider entry to the inflatable before the existing rider has vacated the inflatable cushion.** Repeat the procedure.

- In the event of an emergency:

- **Depress the Emergency Stop button and remove the key; then turn off the mains power switch. Instruct the players to evacuate the ride safely offering assistance if it is safe to do so. Once the riders have evacuated the ride, unplug the control console and blower from the mains power outlet.**

In the event of loss of power to the inflatable -thus causing the inflatable to deflate:-

- **Depress the Emergency Stop button and remove the key; then turn off the mains power switch. Instruct the players to evacuate the ride safely offering assistance if it is safe to do so. Once the players have evacuated the ride, unplug the control console and blower from the mains power outlet.**

The Emergency Stop button MUST always be depressed and the key removed whenever you are setting up the game or leaving the control console unattended.

6. SPECTATORS

Do not allow spectators to sit/lean on or around the inflatable. We would recommend wherever possible to have an additional external barrier (see diagram example in page 10 and 11).

7. RIDER HEIGHT & WEIGHT

We recommend a minimum user height of 48 inches and a maximum weight of rider of 300lbs., **except the dedicated children's rides.** For those,



Operating Your Low Profile Motion Base

we recommend a maximum user height of 42 inches and a maximum weight of rider of 250lbs.

use this ride. **THE OPERATORS' DECISION IS ALWAYS FINAL.**

8. CORRECT RIDING POSITION

To keep the ride safe and to ensure the longevity of the equipment, please ensure the rider uses the correct position:

- Placing their feet in the footprints of the attachment cover.
- Facing towards the operator.
- Bending their knees slightly.
- Putting their arms out in a "surfing position" for balance.

9. MANUAL CONTROL

There is a 8 position manual joystick that can be used in conjunction with the ten speed control dial. As soon as you let go of the joystick the ride stops. The speed controls have no effect on the pre-set automatic programs.

13. WHO SHOULD NOT RIDE

People should not use this ride if the rider:

- Is Pregnant.
- Cannot mount the ride and hold on securely.
- Is under the influence of alcohol or drugs.
- Suffers from any of the following: Epilepsy, Muscular Complaints, Neck or Spinal (back) problems, or any other Physical Ailment that will inhibit the rider to ride safely.

14. DYNAMIC INFORMATION

- The recommended minimum operating space required is:

- Low Wall Wave Inflatable | Xtreme Board Combo | Angus McRodeo: 18' x 20' x 10' headroom.
- Big Wave Inflatable: 20' x 20' x 13' headroom.

- Weights of individual components:

- Motion base: 200lbs.
- Ride attachment: 25-100lbs.
- Control console: 85lbs.
- Inflatable: 120lbs.
- Electric blower: 30lbs.
- Stabiliser legs x 4: 28lbs.
- Total unladen load combine weight of the system when erected: 488-563lbs. (depending on ride attachment).
- Total maximum laden load (with heaviest rider): 863lbs.

- Maximum speeds:

- Buck motor: 43.8rpm. (4.6 rad./s.).

- Power requirements:

- The system operates from 110 volts single phase electricity 60hz. drawing 8 amps.
- The 1hp. inflation blower for the inflatable operates from 110 volts single phase electricity 60hz. drawing 7 amps.
- Maximum air volume: 1170cfm.

10. GENERATORS

PLEASE NOTE: THE USE OF PORTABLE GENERATORS TO POWER THE MACHINE CAN DAMAGE THE ELECTRONICS.

If you must use a portable generator, invest in a branded generator such as Honda, Kawasaki or Briggs & Stratton. You will need a 3KVA diesel powered generator, as these give the best power and performance. Use an in line power surge protector between the generator and the control console.

11. KEEPING YOUR MACHINE SAFE

Whenever the machine is left unattended, switch off the isolator and press the Emergency Stop button. Make sure the key is removed. DO NOT use the Emergency Stop button to stop the ride. Use the normal stop button to stop the ride.

12. STANDARD DISCLAIMER

This ride is designed to throw people off. If any participant has any concern for their safety with regards to falling off the ride then they should not



Operating Your Low Profile Motion Base

- Maximum static pressure: 8.8 inch.
- **DO NOT operate when it is raining or snowing as there is a risk of electrocution.** In the event of a sudden rain/snow storm:
 - Evacuate the ride.
 - Turn off the control console and blower and disconnect the mains power cords from the electrical supply.
 - Remove the control console & blower to covered shelter.
 - Ensure that a tarpaulin or similar water proof cover is placed securely over the inflatable, attachment & motion base to prevent water damage. Once it has stopped raining/snowing, uncover the inflatable & motion base and check that there is no water leakage to these parts; ensure that any standing water is removed and or relocate the bull system to a dry location. **AT NO TIME should you use any electrical device when wet.**
- DO NOT operate in winds of more than 20mph.

15. RIDE ATTACHMENTS

The Low Profile motion base is only used with stand up/on ride attachments such as surf boards, snowboards or skateboards, and the sit on rides such as Angus McRodeo, Shane the Sheep and Pippa Pig.



RULES OF PLAY

- DO**
- ✓ Place your feet in the footprints of the attachment cover.
 - ✓ Face towards the operator.
 - ✓ Bend your knees slightly.
 - ✓ Put your arms out in a "surfing position" for balance.
 - ✓ **HAVE FUN!**

- DON'T**
- Allow more than ONE rider at any one time.
 - Stand straight on the surfbarod, skateboard or snowboard.
 - Grab/Hold any parts of the sweeper arms.

-
- **NO SHOES**
 - **NO SHARP OBJECTS**
 - **NO GLASSES**
 - **NO FLIPS**
 - **NO FIGHTING & NO ROUGH HOUSING**
 - **NO CHEWING GUM**
 - **NO FOOD**
 - **NO DRINK**
 - **NO HATS**
 - **NO CLIMBING ON WALLS**

WHO SHOULD NOT PLAY. People should not use this ride if the player:

- Is shorter than 48 inches and/or heavier than 300lbs.
- Is Pregnant.
- Is under the influence of alcohol or drugs.
- Suffers from any of the following: Epilepsy, Muscular Complaints, Neck or Spinal (back) problems, or any other Physical Ailment that will inhibit the participant to ride safely.



Serial Number Location

There are 2 ID plates on your equipment, which include the following:

- Manufacturer Details
- Serial Number
- Power Requirements

These ID plates can be found in these 2 locations:



On the outside of the motion base above 10-pin and 6-pin connection.



Over the power plug on the outside of the control console.



Trouble Shooting

Your High Profile Motion System has been meticulously engineered and thoroughly tested before delivery. If, however, you unexpectedly experience difficulties please check out the guide below. **We DO NOT warranty any parts that are damaged from using a generator.** If you have any questions or need help please contact us on: 941 697 0324 or sales@galaxymultirides.com.

POWER REQUIREMENTS

REGION	POWER REQUIREMENTS
Europe/Asia/South America/Australasia	220 volts mains power single phase 10 amps
North America	110 volts mains power single phase 20 amps
Japan	90 -110 volts mains power single phase 20 amps

SYMPTOMS

ISSUE	SOLUTION
WHAT IS THE POWER SOURCE	We recommend to work on mains power. THE USE OF PORTABLE GENERATORS TO POWER THE MACHINE CAN DAMAGE THE ELECTRONICS. But, if you must use a portable generator, invest in a branded generator such as Honda, Kawasaki or Briggs & Stratton. You will need a 3KVA diesel powered generator, as these give the best power and performance. Use an in line power surge protector between the generator and the control console.
HOW MANY AMPS ARE NEEDED	A surf ride -or any other attachment in the low profile motion base- requires 8 amps.
WHAT IS THE OUTPUT POWER FROM THE POWER SOURCE	A surf ride -or any other attachment in the low profile motion base- requires 110-120 volts.
LENGHT OF THE EXTENSION CORD AND GAUGE OF THE POWER CORD	Longer thinner power cords will always lose voltage.
THE RIDE IS REALLY SLOW	Check that you have enough voltage & amps to the machine. Once you go over a 30' extension cord this can contribute to voltage drop: the longer the cord, the worse the problem will be.
THE RIDE MOVES FREELY WHEN IT'S NOT POWERED WHEN I MOVE IT	This is called back driving. It is a characteristic of this type of gearbox. Please be assured it has NO DETRIMENT to the machine at all. It will not happen when the machine is in operation.



Trouble Shooting

ISSUE: THE MACHINE WON'T BUCK
SOLUTIONS:



Is the Emergency Stop button released? Gently turn the key to the right, let go and the button pops up.



Is the LED display on the inverter showing as ready/**rdy**? If not refer to Appendix 1.



Can you hear the motor humming (making noise) as if it is receiving power?

- If yes, the machine is missing a phase. There must be a loose wire/connection in either one of the cords or socket on the motion base or socket on the console. Open up every plug and socket and check the connections. Inspect all cords for any damage that may create a short.
- If not, we recommend a qualified electrician does a continuity test with a meter to determine what parts of the machine are receiving power.



Does the motor move when the impeller is manually moved? Rotate the fan blade by inserting a small screwdriver several times through the air grill pushing on the fan blade. If the motor makes connection with the gear box you will see the machine move fractionally. This means the motor and gearbox are ok and the problem is electrical. If you cannot get it to move, then the issue may be mechanical and the motion base would have to be returned for inspection.

Trouble Shooting

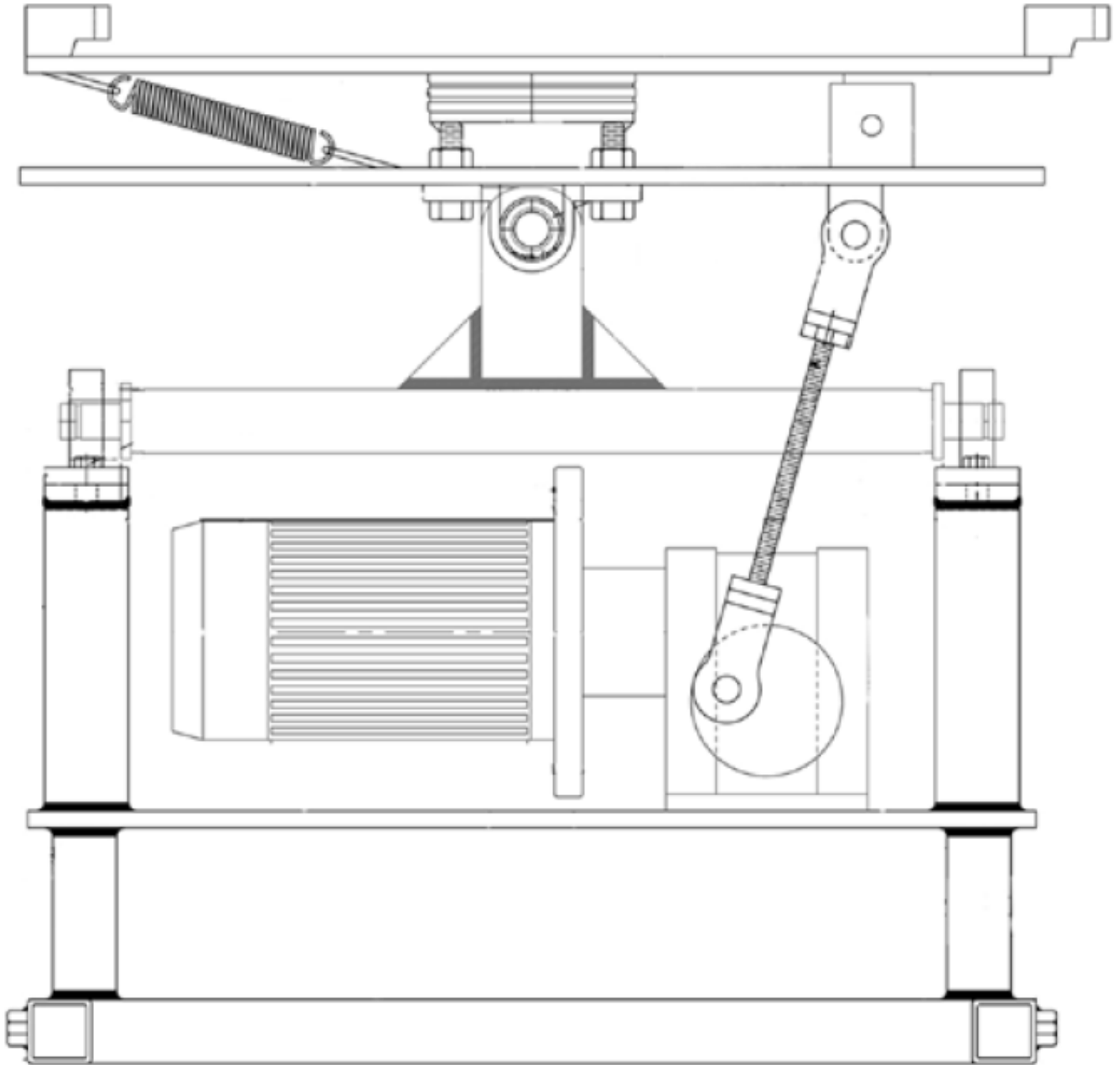

Maintenance

ITEMS	MAINTENANCE
Inflatable	Wash down with warm soapy water.
Electric Cables	Before each new event, check the electric cables and connections for wear or damage.
Lubrication	<p>Lubricate the bushes, rods, bearings, & all moving parts every month (see maintenance schedule in the next page).</p> <p>All grease nipples should be lubricated using Pennzoil Multi Purpose 302 EP (NLGI #2 Lithium grease).</p> <p>All the grease nipples are easily accessible and exposed on the motion base. If the buck arm rod ends on the High Profile Motion Base do not move easily from side to side (left to right) the buck motion may slow or stop.</p> <p>Contact Galaxy Multi Rides calling to the phone number 941 697 0324 or emailing at customerservice@galaxymultirides.com for replacements.</p>
Nuts, Bolts and Fixings	Check all nuts, bolts and fixings are tight on a weekly basis.
Cleaning	Use spray polish to clean all high finish GRP surfaces.



Safety Check Routine (TO BE PERFORMED AT EVERY EVENT)

ITEMS	M	T	W	T	F	S	S
Check all electrical connections on all plug sockets							
Check all nuts and bolts are secure							
Check lubrication points. Lubricate if necessary							
Check all bearings							
Check all rod ends							
Check all fixings for the ride							
During the event, check the ride periodically to secure connection to the motion base							
Check inflatable bed for holes and wear and tear							
Where applicable, ensure the inflatable is securely anchored to the subfloor							
Check the safety padding for holes and wear and tear							
Check the electric fan blower							
Check the security of the grab handle on the ride wear if applicable							
Automatic program buttons							
Check the Stop/Start button							
Check the joystick control							
Check the manual speed dial							
Check the mains isolator							
Check the Emergency Stop button							

WARNING

DURING AN EVENT CHECK PERIODICALLY THAT THE BOLTS IN THE ATTACHMENT ARE TIGHT.



Low Profile Motion Base Lubrication Points

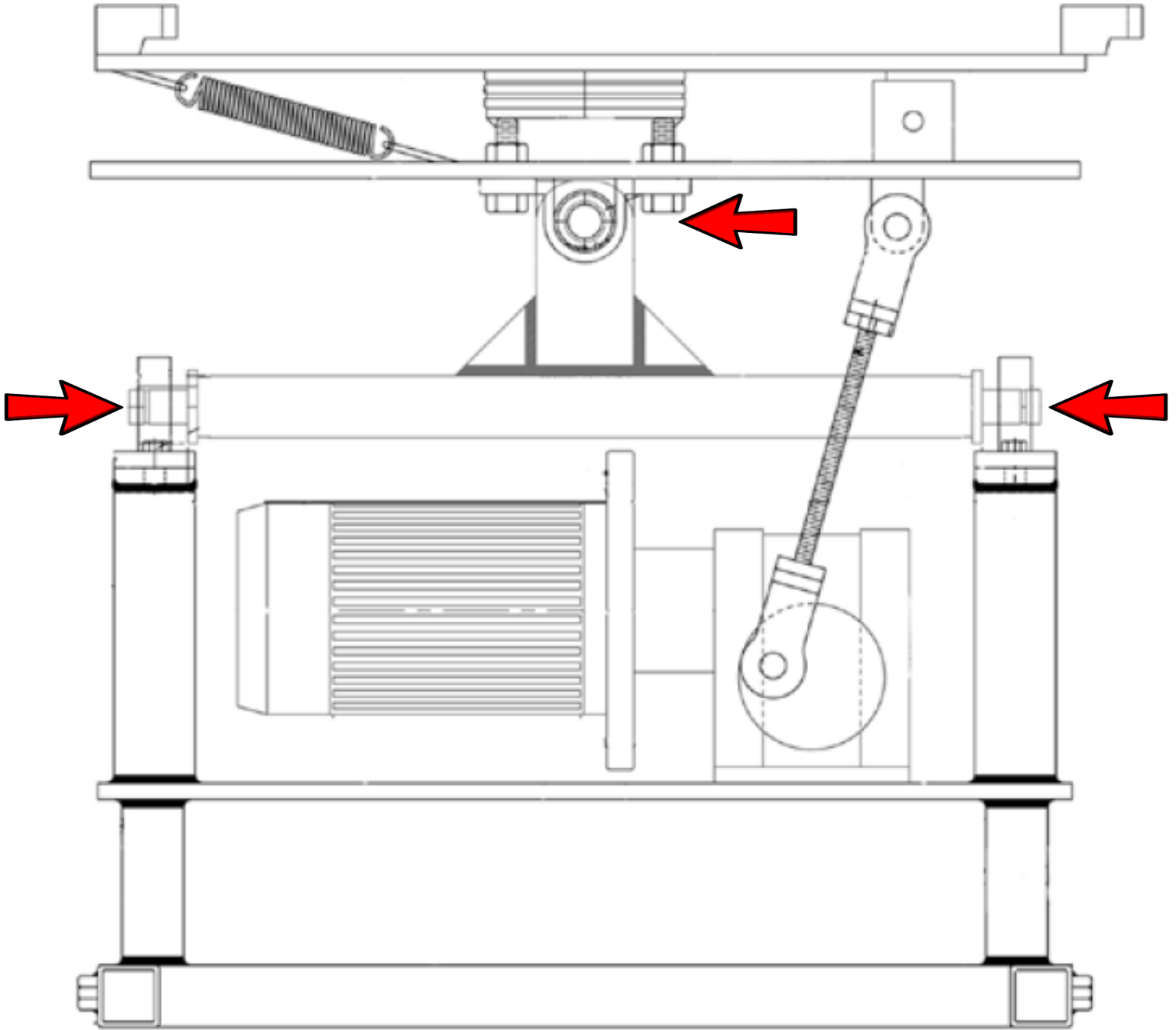

Risk Assessment for the Galaxy Multi Ride

This risk assessment is specifically for the Galaxy Multi Ride and is not applicable to any other brand of mechanical multi ride system.

1. RISK

Sudden deflation of inflatable surround.

SOLUTION

Stop the ride immediately and dismount the rider.

Check the blower: is there power to the blower?

- If no, check fuse and mains supply and power cable for any damage.
- If yes, check the air intake on the blower is not blocked. Check & ensure deflation zips are fully closed. Check to make sure there are no tear's or holes in the inflatable.

2. RISK

The motion base is rocking & unstable.

SOLUTION

Stop the ride immediately and dismount the rider; ensure that you have secured the four steel stabiliser legs into the motion base properly.

3. RISK

The ride attachment is loose and wobbling as soon as the rider tries to get on.

SOLUTION

Stop the ride immediately and dismount the rider. Ensure that the attachment is connected to the top of the motion base correctly and ensure that all three screw bolts are securely tightened.

4. RISK

The view of the operator is obscured by the audience.

SOLUTION

Stop the ride immediately and dismount the rider. Ensure that the control console is pushed up to the edge of the inflatable cushion so no one can stand in front of the operator.

5. RISK

Trip hazard from trailing cables.

SOLUTION

Ensure all trailing cables & cords are taped to the sub floor or covered with a suitable matting or trunking.

6. RISK

The rider is able to touch the ceiling or hanging light.

SOLUTION

Stop the ride immediately and dismount the rider. The minimum headroom required is 10' (3m.). Do not use the bull in buildings or areas with any less headroom.

7. RISK

Potential collision by the rider with a member of the audience.

SOLUTION

Stop the ride immediately and dismount the rider. Ensure that no member of the public/audience is allowed to sit on the edge of the inflatable surround, erect a secondary perimeter barrier 3' (1m.) away from the edge of the inflatable surround.



Release of Liability and Assumption of Risk

In consideration of the services of _____, its employees and agents (collectively, "_____"), I agree to release, hold harmless and indemnify _____, on behalf of myself and my family members, partners, heirs and assigns as follows:

1. I acknowledge that riding a _____ (name of the ride) entails risks that could result in physical or emotional injury, paralysis, death, injury or damage to me, to property, or to third parties. I understand that the risks cannot be eliminated without jeopardizing the essential qualities of the activity. The risks could result in musculoskeletal injuries, including head, neck, and back injuries.
2. I accept and assume all the risks of participating in this activity. My participation in this activity is purely voluntary, and I elect to participate in spite of the risks.
3. **I release and agree to indemnify and hold harmless _____ from any claims** that are in any way connected with my participation in this activity or my use of _____ equipment or facilities, **including claims that _____ was negligent.** However, I do not release any claims related to intentional or reckless acts by _____.
4. I have adequate insurance to cover any injury or damage I may cause or suffer while participating or I agree to bear the costs of any injury or damage.
5. I agree that, if I bring a lawsuit against _____, I will do so solely in the State of _____ and the substantive law of the State of _____ will apply in that lawsuit without regard to the conflict of law rules. I agree that if any portion of this agreement is found to be void or unenforceable, the remaining portions shall remain in full force and effect.

By signing this document, I acknowledge that if that anyone is hurt or property is damaged during my participation in this activity, I may be found by a court of law to have waived my right to maintain a lawsuit against _____ on the basis of any claim from which I have released them. I have had sufficient opportunity to read this agreement. I have read and understood it, and agree to be bound by its terms.

Signature of Participant: _____

Print Name of Participant: _____ Date: _____

PARENT'S OR GUARDIAN'S ADDITIONAL INDEMNIFICATION (Must be completed for participants under the age of 18)

In consideration of _____ ("Minor") being permitted by _____ to participate in its activities and to use its equipment and facilities, I further agree to indemnify and hold harmless _____ from all claims which are brought by or on behalf of Minor and which are in any way connected with Minor's use or participation. I have full authority to sign this agreement on behalf of Minor.

Signature of Parent or Guardian: _____

Print Name of Parent or Guardian: _____ Date: _____



Incident Report

OWNER'S NAME:

TRADE NAME:

ADDRESS:

PHONE NUMBER:

TODAY'S DATE:

LOCATION OF THE INCIDENT:

DATE AND TIME OF THE INCIDENT:

NAME OF PERSON FILLING THE FORM:

TITLE OF PERSON FILLING THE FORM:

INFORMATION OF THE PERSON INJURED AND INCIDENT	
FULL NAME	
AGE	
ADDRESS	
INCIDENT SEVERITY	
DESCRIBE THE NATURE OF INJURY	
WEATHER CONDITIONS	
DESCRIPTION OF INCIDENT	
NAME OF OPERATOR	
WITNESSES (include names, addresses, and relation to the owner or injured)	

DISCLAIMER: This checklist is intended as a suggested guideline. It is recommended that an incident report include but should not be limited to the items listed on this form.



FR Test Certificates



8385 White Oak Avenue
Rancho Cucamonga, CA 91730
909.483.0250 ph. | 909.483.0338 fx.

CLIENT: Plato Chemical
BLK1, M/FL, Sun Cheong Ind. Bldg. 1 Cheng Shun St.
Cheung Sha Wan, Kowloon, Hong Kong, China

Test Report No: RJ8620F-1	Date: August 15, 2022
----------------------------------	------------------------------

SAMPLE ID: The test samples are identified as: *PVC Vinyl. Nominal thickness 0.0230"*

SAMPLING DETAIL: Test samples were submitted to the laboratory directly by the client. No special sampling conditions or sample preparation were observed by QAI.

DATE OF RECEIPT: Samples were received at QAI on July 21, 2022.

TESTING PERIOD: August 12, 2022.

AUTHORIZATION: Testing authorized by Lisa Yu QAI proposal No. 22RT0706-01, signed on July 06, 2022.

TEST REQUESTED: The sample material was tested in accordance with the procedures outlined in NFPA 701-19, Method 2 "Standard Methods of Fire Tests for Flame Propagation of Textiles and Films, flat specimens, Original Condition and 72 hrs water leaching.

TEST RESULTS: The PVC Vinyl material has met the performance requirements Per the Performance Criteria outlined in NFPA 701-2019. See page 2 for detailed results.

Prepared By

Victor.A.Peinado
Senior Fire Technician

**Signed for and on behalf of
QAI Laboratories, Inc.**

Jason Friedrich P.E.
Engineering Manager

Page 1 of 4

THIS REPORT IS THE CONFIDENTIAL PROPERTY OF THE CLIENT ADDRESSED. THE REPORT MAY ONLY BE REPRODUCED IN FULL. PUBLICATION OF EXTRACTS FROM THIS REPORT IS NOT PERMITTED WITHOUT WRITTEN APPROVAL FROM QAI. ANY LIABILITY ATTACHED THERETO IS LIMITED TO THE FEE CHARGED FOR THE INDIVIDUAL PROJECT FILE REFERENCED. THE RESULTS OF THIS REPORT PERTAIN ONLY TO THE SPECIFIC SAMPLE(S) EVALUATED.

WWW.QAI.ORG
info@qai.org

FIRE TESTS FOR FLAME PROPAGATION

SAMPLE PREPARATION CHAPTER 13.1

Test was conducted in accordance with NFPA-701 2019 edition. 10 Specimens were prepared from the submitted sample for original condition. Specimens were cut 125 mm x 1200 mm from the sample roll. The specimens were cut with the long dimension in the direction of the lengthwise of the material.

CONDITIONING:

The specimens were conditioned at a temperature of 68° F ± 9°F for at least 24 hours prior to testing.

TEST PROCEDURE

The flame was applied vertically at the center of the width of the lower end of the specimens for 2 minutes, then withdrawn, and the duration of flaming in the specimens after withdrawal of the burner recorded. After complete extinction of all flame and glow in the specimen, the length of char was measured.

TEST RESULTS ORIGINAL CONDITION:

Specimen No.	Char Length (inches)	After Flame, (seconds)	Time of Flaming of pieces on floor (seconds)
1	9	0	0
2	10	0	0
3	13	0	0
4	15	0	0
5	15	0	0
6	12	1	0
7	13	0	0
8	9.5	1	0
9	11	1	0
10	12	2	0

THIS REPORT IS THE CONFIDENTIAL PROPERTY OF THE CLIENT ADDRESSED. THE REPORT MAY ONLY BE REPRODUCED IN FULL. PUBLICATION OF EXTRACTS FROM THIS REPORT IS NOT PERMITTED WITHOUT WRITTEN APPROVAL FROM QAI. ANY LIABILITY ATTACHED THERETO IS LIMITED TO THE FEE CHARGED FOR THE INDIVIDUAL PROJECT FILE REFERENCED. THE RESULTS OF THIS REPORT PERTAIN ONLY TO THE SPECIFIC SAMPLE(S) EVALUATED.

FIRE TESTS FOR FLAME PROPAGATION

SAMPLE PREPARATION CHAPTER 13.1

Test was conducted in accordance with NFPA-701 2019 edition. 10 Specimens were prepared from the submitted sample for original condition. Specimens were cut 125 mm x 1200 mm from the sample roll. The specimens were cut with the long dimension in the direction of the lengthwise of the material.

CONDITIONING:

The specimens were immersed in tap water for 72 hours. After the immersion period the samples were dried out at a temperature of 68° F ± 9°F for at least 24 hours prior to testing.

TEST PROCEDURE

The flame was applied vertically at the center of the width of the lower end of the specimens for 2 minutes, then withdrawn, and the duration of flaming in the specimens after withdrawal of the burner recorded. After complete extinction of all flame and glow in the specimen, the length of char was measured.

TEST RESULTS 72 HOURS WATER LEACHING:

Specimen No.	Char Length (inches)	After Flame, (seconds)	Time of Flaming of pieces on floor (seconds)
1	8.5	0	0
2	8	0	0
3	8	0	0
4	12	0	0
5	12.5	0	0
6	7	0	0
7	16.5	0	0
8	9	0	0
9	11	0	0
10	11	0	0

THIS REPORT IS THE CONFIDENTIAL PROPERTY OF THE CLIENT ADDRESSED. THE REPORT MAY ONLY BE REPRODUCED IN FULL. PUBLICATION OF EXTRACTS FROM THIS REPORT IS NOT PERMITTED WITHOUT WRITTEN APPROVAL FROM QAI. ANY LIABILITY ATTACHED THERETO IS LIMITED TO THE FEE CHARGED FOR THE INDIVIDUAL PROJECT FILE REFERENCED. THE RESULTS OF THIS REPORT PERTAIN ONLY TO THE SPECIFIC SAMPLE(S) EVALUATED.

PERFORMANCE CRITERIA

- 1) When any specimen continues flaming for more than 2 seconds after the flame is removed from the contact with the specimen, the material shall be recorded as having failed the test.
- 2) When the char length of any single flat specimen exceeds 435mm (17.1 in.) the material shall be recorded as having failed the test.
- 3) When at any time during or after the application of the test flame, any portions or residues of the material being tested breaks or drips from the specimen and fall to the floor of the test apparatus, and continue burning for more than 2 seconds after reaching the floor of the test apparatus, the material shall be recorded as having failed the test.

Photograph

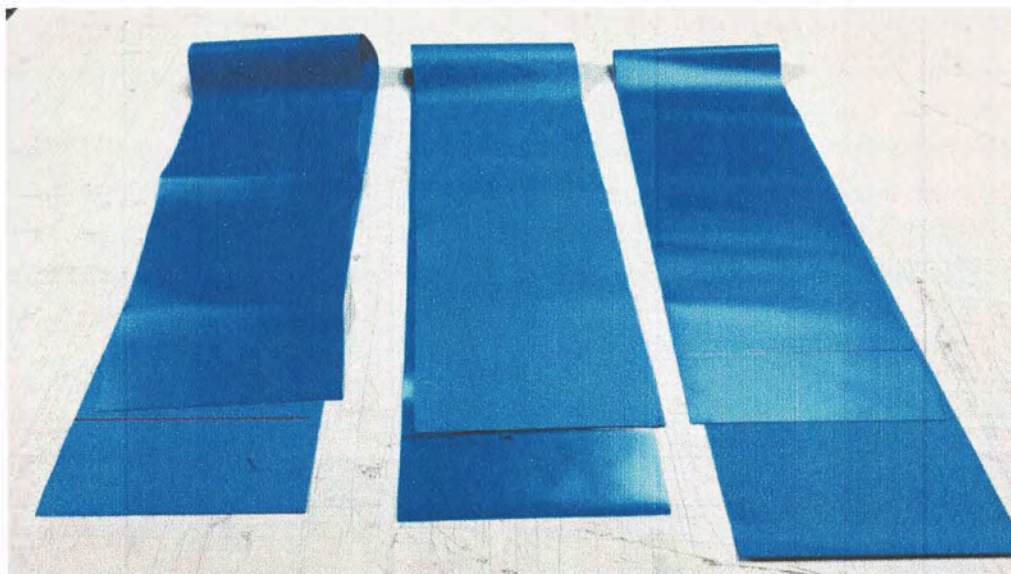

Photo #1

PVC Vinyl. Nominal thickness 0.0230"

******End of Report******

THIS REPORT IS THE CONFIDENTIAL PROPERTY OF THE CLIENT ADDRESSED. THE REPORT MAY ONLY BE REPRODUCED IN FULL. PUBLICATION OF EXTRACTS FROM THIS REPORT IS NOT PERMITTED WITHOUT WRITTEN APPROVAL FROM QAI. ANY LIABILITY ATTACHED THERETO IS LIMITED TO THE FEE CHARGED FOR THE INDIVIDUAL PROJECT FILE REFERENCED. THE RESULTS OF THIS REPORT PERTAIN ONLY TO THE SPECIFIC SAMPLE(S) EVALUATED.

Manufacturer's Inspection

RIDE:

LOCATION:

ITEMS	COMMENTS
Unit inflates properly	
Seams are inspected	
Doors are inspected for proper fit	
Spouts are inspected	
Zippers inspected	
Unit is coded	
Instructions and labels included	
Sand bags and/or stakes included	
Hadware included	
Hardware inspected	
All tie downs are in place	
All anchor points are sound	
Unit has correct amount of inflation (no sagging or buckles in walls, floor and roof)	
Motion base and control console inspected	
Ride attachment inspected	
General	

SHIPPED TO

MANUFACTURER: Galaxy America	REF: ASTM F 846-92
-------------------------------------	---------------------------

I, _____, hereby certify as follows:
 _____ has been inspected and tested upon completion of assembly and
(RIDE NAME)
 prior to shipping to _____ . _____ is in proper
(PURCHASER) (RIDE NAME)
 and safe working order.

Signature: _____ Date: _____



Terms and Conditions of Sale

GALAXY AMERICA, INC. (“Company”) hereby offers its products for sale to the buyer described on the front of this form (“Buyer”) upon the terms and conditions contained herein (“Terms”). The parties agree that the Terms shall govern the contract of sale between Company and Buyer. If any terms differ between this document and any Buyer-drafted document, these Terms shall govern and control.

A. GENERAL CONTRACT TERMS & CONDITIONS

1. Company agrees to honor all price quotations for thirty (“30”) days from the date of the written quotation (subject to the availability of the goods as of the date the order is confirmed by the Company).
2. Order acceptance by Buyer constitutes an unqualified acceptance of Company’s written quotation and its contents, conditions, and Terms.
3. Buyer’s acceptance of the goods at delivery is conclusive evidence Buyer accepts the goods’ condition.
4. Buyer shall maintain in force, and shall continue to maintain in force at all times while it owns, operates, lends or leases the goods being sold by Company (“Company product”), whether directly or through any third-party, employee, agent or independent contractor, insurance with a carrier(s) with financial strength of at least A-VIII or better as defined by AM Best with minimum limits of liability of no less than One Million Dollars (\$1,000,000) per occurrence to cover any and all general, personal injury and product liability claims that may be brought with respect to Company product, including any and all claims that may be brought by a customer(s) or other individual(s) if they are injured, directly or indirectly, in any manner whatsoever, by reason of using or otherwise interacting with Company product sold to Buyer. Buyer will arrange for Company to be named as an additional insured on Buyer’s insurance policy and shall arrange for a Certificate of Insurance evidencing such coverage to be provided to the Company by Buyer’s insurance carrier no later than fourteen (14) calendar days after the date of shipment, and in any event, prior to the operation or use of the goods in any manner. It is agreed between the parties that this paragraph 4 shall be a material term of this agreement.
5. Buyer agrees that the products sold by Company are specifically designed for their intended use only and must not be altered, abused or misused in any way. Alteration, abuse or misuse of Company product may cause injury to persons or property. Company expressly disclaims and Buyer hereby assumes liability for any claim arising out of the actual or alleged alteration, abuse, misuse, failure to repair or maintain, or any other action or inaction taken with respect to Company product. Buyer further agrees to indemnify, defend and hold Company harmless for and against any claims arising out of any alteration, abuse or misuse of any Company product as well as any act, error or omission in the operation of a Company product. Further, Buyer agrees that the Terms of this agreement shall survive transfer or sale of the device to any third party and that it is incumbent upon Buyer to advise any third party or transferee of same, and to have any transferee affirmatively execute a Joinder Agreement satisfactory to Company to assure that such third party or transferee will be legally bound thereby, and that Buyer will continue to be legally bound thereby, with such Joinder Agreement to be prepared by Company at the expense of Buyer, with Company to have the right to approve the identity, reputation, and financial wherewithal of employees from any and all liability or obligation for injury or damages as the result of such use, except to the extent clearly attributable to the gross negligence or willful misconduct of Company and its employees, contractors, or affiliates.
6. In no event shall Company be liable for any direct, indirect, punitive, incidental, special or consequential damages, to property, person or life, whatsoever arising out of or connected with any use or misuse or lack of repair or maintenance, of Company’s products.



7. Each heading contained in this Agreement is used for convenience purposes only and is not intended to define, expound upon or limit the provisions which immediately follow such paragraph heading.
8. Any reference to a word in this Agreement shall include the plural, singular, masculine, feminine

B. CHANGES IN PRODUCT SPECIFICATIONS

1. Descriptions, illustrations, specifications, drawings, and particulars of weights and dimensions in quotes, proposals, catalogs, advertisements, or any other documents are approximate only. Company's goods include design and artistic work that is not capable of precise definition and Company's obligation to supply goods to Buyer is limited to supplying goods reasonably in compliance with any specifications provided. Company reserves the right to change its products at any time without notice, including changes in materials, dimensions, colors, and design.

C. COMPLAINTS AND LIMITED WARRANTY

1. Any implied warranty of merchantability, implied warranty of fitness for purpose, and warranty of title are expressly and knowingly and expressly waived by Buyer. There are no warranties, express or implied, which extend beyond those provided for herein. Company's liability with respect to any defect in goods or for any loss, injury, or damage attributable thereto shall be limited to one of the following as determined by the Company in its sole and absolute discretion: (a) repairing defective goods at the Company's facilities with Buyer being responsible for transporting the goods to and from the facilities and all costs of repair, or (b) supplying new goods in exchange for defective goods. No warranty claim shall be valid unless and until: (a) the claim is specifically detailed in writing to Company within the specific warranty period of the goods' delivery date, and (b) Company has examined the goods (in the case of returned goods), and (c) goods are installed and demonstrated at the time of installation by the Company or correctly installed by Buyer as directed by the Company meeting all of the Company's standards and specifications, as Company may direct and where Buyer has complied with the Terms of this agreement.

2. Buyer agrees that the goods have a limited life, the length of which is determined by numerous factors, including the amount of use, regular inspection and maintenance, misuse, abuse or improper storage. Consequently, goods used extensively will not last as long as goods used occasionally. Buyer agrees that it has no claim for any loss or damage due to normal wear and tear resulting from use, misuse, abuse or failure to regularly inspect and maintain Company's goods or improper storage. Play items fitted on inflatable products are subjected to abnormal wear and shall not be the subject of a warranty claim of any nature and Buyer expressly and knowingly waives any such warranty. Any defect arising from misuse, abuse, or failure to adhere to the Company's operational, inspection or maintenance instructions shall automatically invalidate any and all warranties. Rubber/foam heads, horns and ears, bull hide, grab ropes, jack plugs, sockets connections, plugs, carpet/vinyl base, foam products and elements, graphics, artwork and any other consumable or parts subject to normal wear and tear, are not covered by any warranty whatsoever.

3. All goods returned to Company for work under warranty or work undertaken at Buyer's request and at its sole cost, shall be returned in a clean and dry condition properly rolled and/or packed. Should the Company determine that the goods are not in fit condition as to cleanliness, Buyer shall bear all costs of putting such goods in fit condition by removing them for cleaning or providing labor to return the goods to an acceptable condition. Whether repair work is done under warranty or upon Buyer's commission, Buyer shall be responsible for the cost of freight shipping of all goods to and from Company.



4. Company's products are warranted to the original Buyer only, for a period of one ("1") year from the date of delivery. All warranties are non-transferrable and must be validated by a completed Certificate of Training within thirty ("30") days of Purchase or all Company warranties hereunder shall be null and void. Warranties do not cover normal wear, tear, abuse or accidental damage.

5. Company's products do not include Buyer-serviceable parts. All goods must be returned to Company for warranty service, inspection or repair. Any repair(s) or alteration of Company's products performed by or on behalf of Buyer shall void all warranties and transfer liability for any damages to Buyer.

D. PRICES

Unless otherwise agreed to in writing by Company and Buyer:

1. All prices quoted are for goods Ex Works. 7431 Sawyer Circle, Port Charlotte, FL 33981, and exclude all taxes and other charges, including, but not limited to, import duties, landing, and warehousing charges;
2. A 50% nonrefundable deposit is due on the date of Buyer's order; and,
3. Final balances are due in cleared funds in U.S. dollars prior to the ship date.
4. Company reserves the right to adjust pricing in the event of fluctuations in the cost of labor, materials, currency exchange rates, or import duty occurring during the manufacturing process.

E. FINANCING

1. If approved by Company, in its discretion, Buyer may finance the purchase of the Company product with a third-party lender ("Financing Company"), and such Financing Company may place a lien upon the Company product and maintain the lien until the Financing Company is paid in full. In such event, Company shall have the right to approve any and all legal documents associated with such financing, and shall have the right to pay the Financing Company any amount(s) that is owed in exchange for the right to receive an assignment of all rights that the Financing Company then has, which will include the right to pursue the Buyer for payment, to repossess the Company product, make such Company product available for sale, and to recover any excess of the amounts not paid over what is received from such sale, which may be a private auction authorized under the Uniform Commercial Code. If Buyer finances the Company product or products Buyer agrees to keep the product or products in good condition, in full working order, available for inspection by Company, and fully insured with Company as a named insured until Company has been paid in full. If Buyer: (a) fails to pay Company any sums due in accordance with the financing terms, (b) breaches any of these Terms, or (c) files for bankruptcy protection, Company shall be entitled to immediately repossess the goods and will have all rights and remedies available to a secured creditor under the Uniform Commercial Code.
2. Notwithstanding anything herein, Company is not obligated to retake possession of the goods. If Company does not repossess the goods, Buyer shall remain responsible for the full price of the goods should the goods be damaged or destroyed or become unusable due to changes in the law, imposition of taxes, or any other reason.



F. DELIVERY/SHIPPING

1. Shipping dates are an indication of Company's endeavor to comply with Buyer requests but not guaranteed and time is not of the essence with respect to any contract. All goods are shipped on an ex works basis and the goods must be paid in full with cleared funds prior to dispatch. Buyer is responsible for the cost of shipping.
2. Delivery is made as of the date Company designates in its notice to Buyer that the goods are available to Buyer at Company's facilities at 7431 Sawyer Circle, Port Charlotte, Florida, 33981.
3. Risk of loss is Buyer's on the delivery date described above notwithstanding Buyer's failure to take possession of the goods. Company shall not be liable for consequential loss or any other loss or damages, whatsoever.
4. Buyer expressly agrees that it is solely responsible for all costs and arrangements associated with picking up, loading, shipping, and insuring the goods from Company's facilities on the delivery date, and will reimburse Company for any and all expenses incurred by Company for such obligations.

G. Order Shipping Information

We would like to reiterate that it is of the utmost importance to inspect your deliveries before signing and accepting the goods. If you are not the receiver of this order, please pass the following information along to the person responsible for receiving the shipment at the delivery address. Galaxy America is not responsible for damage incurred during transit although will assist in the claims process when possible.

All orders are shipped from our facility only after they are inspected for accuracy and quality inspected to ensure that all systems are working properly. Additionally, COMPLETE SYSTEMS will be packed in a custom crate and/or pallet. This is to protect your investment during transit. Cost of materials is included in Shipping as seen on your Order Form

When these shipments are collected by freight carriers, the drivers also inspect the shipment for damage before accepting the cargo and sign a bill of lading stating that the shipment was collected in good condition. This documentation will be passed to you the customer upon delivery. Therefore, when receiving merchandise from a freight carrier, you must make a complete visual inspection before signing the delivery receipt / Bill of Lading.

THE ACT OF SIGNING FOR DELIVERY IS THE ACCEPTANCE THAT YOUR SHIPMENT HAS ARRIVED UNDAMAGED.

1. Do not accept delivery if the product appears damaged. The person who signs the Proof of Delivery (POD) when shipment is delivered MUST note any visible damage on the POD or refuse the shipment. If your order has been damaged during shipment, please call immediately at 941-697-0324. We will then pursue all claims on your behalf through the proper channels with the carriers. If you fail to note any shipping damage on the bill of lading before signing, you have accepted as is, and you will have no legal recourse or claim for damage to your order during shipment. We will NOT accept responsibility for damage that has been done during transit. If there is no notation of damage on the signed Bill of Lading, trucking companies often deny claims of damage. It is their right to do so. It is important that whoever receives the shipment be aware of how to look for damage and note it on the Bill of Lading (Delivery Receipt.) Even if there is no designated space for such a notation, it must be written on the Bill of Lading (Delivery Receipt).



2. If the product has questionable cosmetic damage, is incomplete, or items listed on the delivery receipts or bill of lading are missing, you must properly note this on all copies of the delivery receipt / Bill of Lading and immediately notify Galaxy America. Scuffs and scrapes can happen in transit and do not void your warranty. Shipments may become soiled in transit; this DO NOT constitute damage and this type of damage claims will be refused.
3. Please note: If the delivery receipt is signed without noting the damage or missing items, Galaxy America will not be responsible for collection of claims or replacement of merchandise.
4. Concealed damage, (not detectable at time of delivery), must be reported to Galaxy America within two (2) days, or sooner. However, items should be thoroughly examined at time of receipt. It is the receiver's responsibility to examine all merchandise. Please read all small print on carrier's Bill of Lading for their company rules and regulation details.
5. Truck Access Requirements Trucks up to 65' in length may deliver your merchandise. In most cases they cannot enter private driveways or roads, as there is insufficient room to maneuver and turn around. When this is the case, prior arrangements must be made to deliver your order.

By signing this, you are acknowledging and accepting that you fully understand the responsibility of receiving your goods.

Order Shipping Additional Fees

You will be billed separately, if the following applies to your order:

1. The "ship to" address is not noted as residential, which includes businesses within a residence as well as remote locations: Additional Fee of \$55.00 - \$250.00 to be determined by location and shipment size.
2. Indoor Delivery: Additional fee of \$150.00 - \$400.00 to be determined by location and shipment size.
3. Redelivery: Additional fee of \$150.00 - \$400.00 per occurrence to be determined by location and shipment size.
4. Lift Gate Service after order confirmation Additional fee of \$55.00 - \$200.00 to be determined by location and shipment size.
5. Detention (must accept delivery within 15 minutes of truck arrival) Additional fee of \$55.00 - \$200.00 to be determined by location and shipment size.

H. EXPORT/IMPORT

1. This sales contract is subject to Company's ability to obtain any necessary export permissions.
2. Buyer is solely responsible for obtaining all necessary import permissions.



I. INTELLECTUAL PROPERTY

1. All Company prepared proposals, drawings, designs, brochures, photographs and other materials shall remain the Company's intellectual property and shall not be reproduced, distributed or used in any manner whatsoever without Company's prior written permission.
2. If Buyer provides Company with any specifications or descriptions for use in manufacturing goods, Buyer shall indemnify, hold harmless and defend Company against any and all claims, including any claim that the use of such specifications or descriptions is improper or infringes upon the intellectual property rights of another or violates applicable law or good business ethics.
3. Company reserves the right to display Company's trademark on all goods. Buyer will not remove or deface Company's trademarks, and Buyer will prevent the removal or defacement of Company's trademarks.
4. The provision of any Company goods, materials, proposals, drawings, designs, brochures or other materials provided by the Company shall not be considered a license, express or implied, to such materials or any intellectual property contained therein.

I. GOVERNING LAW AND NOTICE

These Terms and any related contract or agreement between Company and Buyer, and all claims or disputes arising out of or relating in any way to these Terms, any related contract or agreement between Company and Buyer, shall be governed by, and construed in accordance with, the laws of the State of Florida, exclusive of its provisions related to conflicts of law. All disputes under these Terms and any related contract or agreement shall be resolved by the courts of the State of Florida, and shall be submitted solely to the U.S. District Court for the Middle District of Florida (Ft. Myers Division) or the Florida Circuit Court (Business Division) for the Judicial District of Sarasota County, as appropriate, and the parties all consent to the jurisdiction of such courts, agree to accept service of process by mail, and hereby waive any jurisdictional or venue defenses otherwise available. The provisions contained in this Section shall survive the termination and/or expiration of these Terms and any related contract or agreement between Company and Buyer. The Company's Terms and Conditions herein are fully integrated, shall supersede all others and are final. All notices to Company or Buyer shall be by overnight delivery to the addresses listed for the company. The parties hereby **WAIVE ANY RIGHT TO A TRIAL BY JURY**, and further agree that any claim or dispute for more than \$100,000 shall be resolved by arbitration, pursuant to the rules of the American Arbitration Association, with the arbitration proceeding to take place in Sarasota, Florida. There will be only one arbitrator, unless the amount in dispute exceeds \$250,000. The arbitrator will be empowered to impose costs, fees and expenses against the non-prevailing party, or as allocated in proportion to relative fault. The parties waive any right to appeal the decision of the arbitrator or arbitrators to the American Arbitration Association Appellate Department. This is the sole Agreement between the parties, and no previous or future oral agreement shall apply unless in writing and executed by both parties hereto. This Agreement shall not be construed in favor of either party.



J. INDEMNIFICATION AND HOLD HARMLESS

Company shall not be responsible for any action or inaction that it or any employee, contractor, affiliate or related party may conduct or fail to conduct, except to the extent that liabilities or damages are solely the result of gross negligence or willful misconduct on the part of Company, which is demonstrated by clear and convincing evidence. Buyer agrees to indemnify, defend and hold harmless Company for any and all claims for personal injury or property damage, expenses, liabilities, or damage to reputation, goodwill or otherwise that results from a lawsuit, arbitration, or demand letter arising out of the products that are the subject of or arising out of this agreement. Each party further agrees not to disparage the other party under any circumstances, and to keep any dispute, trial or arbitration strictly confidential to the extent legally permitted. The obligations of Buyer under this Agreement shall apply to any person, entity or third party that Buyer shares use, maintenance, occupancy or that Company employs or has employed, any lessee, customer or independent contractor of Buyer, and all terms and conditions of this Agreement shall be binding upon such third parties. The provisions contained in this paragraph shall survive the termination and/or expiration of this agreement and any sale or transfer of the Company's goods by Buyer.



Appendix 1

Electrical Operation and Troubleshooting

Model Year 2022

Revision Reference	Revision Number	Date	By
Initial issue	1.0	17 .11.2022	W.J.Peakman

Contents

Component Identification

Meltdown Principal Parts Description

Auto Bull Principal Parts Description

Inverters

Inverter Likely Faults

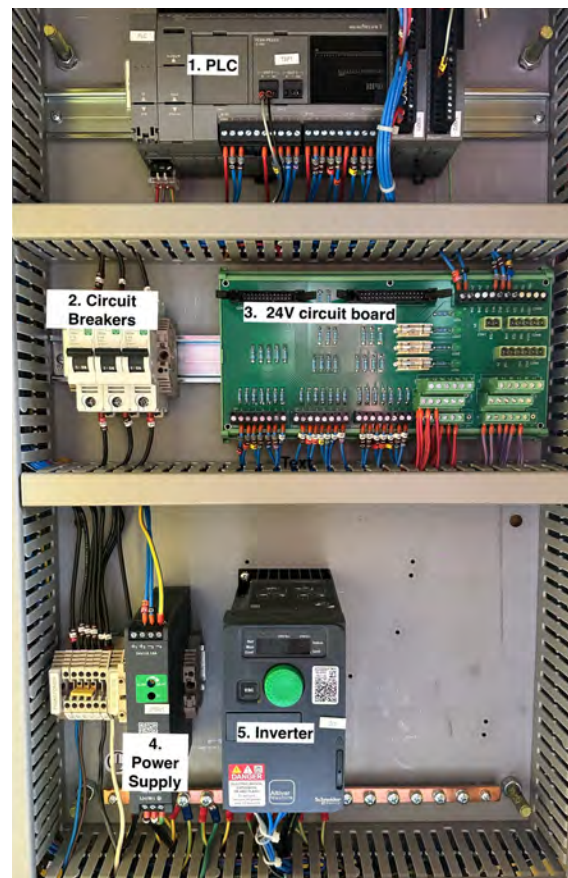

Component Identification

Meltdown Principal Parts Description

2Q1: Circuit breaker, normal position is on (toggle up) protects the front end of the transformer. With this breaker off there will be no power to any of the other working items.

2F1: Fuse, supplies the voltmeter on the panel front, voltmeter will not work with this fuse missing or blown.

3Q1: Circuit breaker, normal position is on (toggle up) protects the inverter drive, with this breaker off the drive will not have any power, in addition the power on light will not illuminate.

3I1: Variable speed drive or inverter, converts single phase fixed frequency power to three phase variable frequency power to drive the motion base spin motor.

Auto Bull Principal Parts Description

PLC: The brain of the system, this unit controls the working of the whole system.

Main PCB: Provides distribution for power and interconnection for your time/best time upgrade, SFX button upgrade and clocks connections.

Three fuses F1, 3Amps main control fuse, F2 0.5A fuse for cut off circuit, F3 2A fuse for SFX. Four LED's LED 1, F1 = OK. LED 2, F2 = OK, LED 3 F3= OK, LED 4 board power OK. All these should normally be on.

2Q1: Circuit breaker, normal position is on (toggle up) protects the front end of the transformer. With this breaker off there will be no power to any of the other working items.

2Q2 Circuit breaker, normal position is on (toggle up) protects the front end of the dc power supply. With this breaker off there will be no dc power to any of the other working items. (PLC, Main PCB, Lights etc.

2F1: Fuse, supplies the voltmeter on the panel front, voltmeter will not work with this fuse missing or blown.

2PSU1: DC Power supply, provides DC power to the whole system, should have an LED lit on the front to confirm correct operation. LED will not show if overloaded, faulty or without power (e.g., 2Q2 off or tripped)

3Q1: Circuit breaker, normal position is on (toggle up) protects the inverter spin drive, with this breaker off the drive will not have any power.

3Q2: Circuit breaker, normal position is closed (on button in), protects the spin resistor 3BR1. When this circuit breaker is tripped the spin inverter is disabled.

3I1: Variable speed drive or inverter, converts single phase fixed frequency power to three phase variable frequency power to drive the motion base spin motor.

4Q1: Circuit breaker, normal position is on (toggle up) protects the inverter buck drive, with this breaker off the drive will not have any power.

4I1: Variable speed drive or inverter, converts single phase fixed frequency power to three phase variable frequency power to drive the motion base buck motor.

Inverter Likely Faults

Often if there is a problem the inverter will find it and shut down in a safe manner indicating the problem with a fault code. Common fault codes and their likely cause and remedies are listed below:

SAFF or STO: Safety fault

- Check connections on estop button and inverter, cycle estop button and console power to reset (leave power off until inverter display stops illuminating when cycling power).

oCF: Overcurrent

- Check associated motor is not stalled, jammed or overloaded.

oHF: Drive overheat

- Console may be in a hot environment or in direct sunlight – leave it to off in a cool location for at least 30 minutes and avoid repeating the problem by relocating in a suitable manner

oLF: Motor overload

- Motor may be overheating, check for free movement, stalling or misuse.

oPF1: 1 phase output loss

- Check for damaged cables, damaged plugs and sockets, damaged wiring and good continuity in motion base slip ring (for buck motors)
- Swap cables/bases to eliminate potential sources of fault and narrow down the search if possible

oPF2: 3 Phase motor phase loss

- Normally disabled so check drive parameters

oSF: Mains overvoltage – supply voltage too high

- Check transformer and supply wiring, mains voltage measured between terminals L and N on the bottom left hand rail should be approximately 230Vac

SCF1: Motor short circuit-fault between 2 or more output phases

- Check for damaged cables, damaged plugs and sockets, damaged wiring, and good continuity in motion base slip ring (for buck motors)
- Swap cables/bases to eliminate potential sources of fault and narrow down the search if possible
- Check motor windings

SCF3: Motor short circuit-fault between 1 or more output phases & ground

- Check for damaged cables, damaged plugs and sockets, damaged wiring, and good continuity in motion base slip ring (for buck motors)
- Swap cables/bases to eliminate potential sources of fault and narrow down the search if possible
- Check motor windings

SCF5: Motor short circuit – a fault between two or more output phases

- Check for damaged cables, damaged plugs and sockets, damaged wiring, and good continuity in motion base slip ring (for buck motors)
- Swap cables/bases to eliminate potential sources of fault and narrow down the search if possible
- Check motor windings

**uSF or
LCR:**

Undervoltage, supply voltage to low

- Check transformer and supply wiring, mains voltage measured between terminals L and N on the bottom left hand rail should be approximately 230Vac
- Is there or has there been during operation an electrical brown out or brief power interruption